

2WD/4WD ROUGH TERRAIN FORKLIFT



2WD/4WD Rough Terrain Forklift

with capacities of 5,000kg



ZHEJIANG HANGCHA IMP. & EXP. CO., LTD.

Factory site: 666 Xiangfu Road,
Hangzhou, Zhejiang, China (311305)

Tel: +86-571-88926735 88926755
Fax: +86-571-88926789 88132890

sales@hcforklift.com
www.hcforklift.com



Follow us on
Facebook



Follow us on
YouTube



Follow us on
WeChat



ISO14001
ISO14001:2015



ISO9001
ISO9001:2015



HANGCHA trucks conform
to the European Safety
Requirements.

2019 VERSION 1 COPYRIGHT 2019/09

HANGCHA GROUP CO., LTD. reserves the right to make any changes without notice concerning colors, equipment, or specifications detailed in this brochure, or to discontinue individual models. The colors of trucks, delivered may differ slightly from those in brochures.

The World of Hangcha



CONCEPT

HANGCHA 5t rough terrain forklift with 2WD/4WD was developed on the basis of the XF series of Hangcha. It adopts the Deutz and Cummins engine, which is powerful and reliable, easy to maintain; It can adapt to the rugged roads in the stone market, timber market, construction sites, etc., as well as the wet and slippery roads in rain and snow.

2WD
ROUGH TERRAIN

4WD
ROUGH TERRAIN



Safety

- / Thanks to the steering oil circuit and the brake oil circuit are independent of each other, thereby reducing the interference of the brake on the steering, the hydraulic braking system is very safe.
- / With the structure of brake valve plus the accumulator, it is safer and reliable.
- / The returned oil filtration device is taken as the standard configuration to extend the service life of the hydraulic elements.
- / OPS function is available for option, work is safer and reliable.

Comfort

- / With the suspension and integrated overhead guard, full-floating transmission, complex engine shock absorber and suspension seat, driving is more comfortable, and the vibration and noise of the truck can be reduced.
- / The extra foot space is provided to reduce operator fatigue significantly, non-slip step makes getting in and out easy and safe. The new designed steering wheel, new brake system and the easy-to-operate levers provide total handling operation.
- / Excellent upward visibility is provided by a large roof screen, in fact, visibility all-round is excellent.

Powerful and reliable engine

- / The 3.6-litre DEUTZ EURO III B/Tier4F-compliant engine produces its peak power (74.3hp/55.4kw) and torque (390Nm) at engine speeds as low as 1300 rpm for great responsiveness.

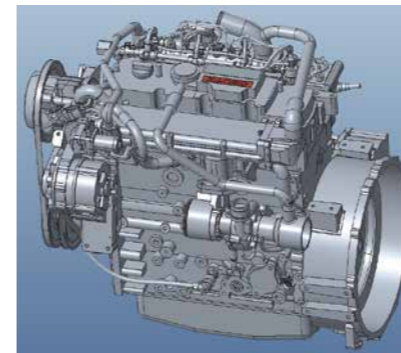

Easy maintenance

- / The two-piece design makes the floorboard easy to lift and remove for access to the power train.
- / The radiator cover can be turned easily by hand to enable quick inspections or servicing.



The easy-to-open hook provides quick access to the engine compartment



Three forward gears- Suspension hydraulic transmission with three forward gears, top speed reach 25km/h



Large screen display, the instrument panel adopts injection molding design, sturdy and durable



Oscillating steer axle allows either wheel to step over obstacles keeping the truck and load level



To achieve maximum productivity, a rough terrain forklift operator needs to be comfortable and in control. We've created a workplace that gets the best from your operators and your machinery

Reliability

- / The reinforced truck chassis with CAE simulation software, optimized design is conducted for the tilt cylinder and steering drive axle installation.
- / Dual air filters and two-stage air filter are taken as the standard configuration to guarantee that the engine can operate for long time and under the optimal status.
- / Deutz engine adopt, "TCI+CR+EGR+DOC" technical route. Adopt EURO III B/Tier4F emission can be met, and it is energy-saving and environment-friendly; A turbo engine further enhances performance at low engine speeds for improved power and tractive effort.



The differential is specifically designed for rough terrain and features manual differential lock providing ultimate traction during inclement weather conditions and rough operating surfaces, it differential lock prevents power loose when one wheel spins.



Full-floating hydraulic drive gear box has the function of switching between 2WD and 4WD, and can provide higher run speed and stronger climbing ability;

Higher specification fork mounting level-3B, more weight can be loaded.



Front tyre

Rear tyre



Productivity

The transmission system gets the maximum performance from the engine without reaching high revolutions, which provides fuel saving, noise level reduction and engine life increase.



The new Dynamic load sensing hydraulic steering system contributes to reduce loss of hydraulic and improve energy efficiency.



The new efficiency lighting system employs LED illuminant and new type reflector to reduce energy consumption, improve significantly illumination performance and prolong work time.

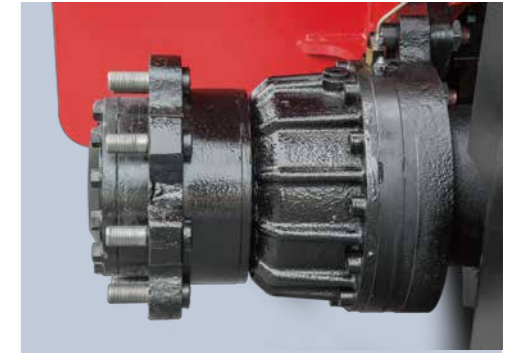

Wet brake offers maximum service life for your brake system.

Maneuverability

The distance to ground is 370mm, it offers greater maneuverability and keep the truck moving in the roughest of applications, and yet we keep a very low center of gravity, by using a distributed weight in the forklift, giving it an excellent stability.





Standard specification

- / Counterweight cover
- / Full-suspension seat
- / Dual air filters
- / High-position exhaust
- / Fuel tank cover (with lock)
- / Fan protection device
- / Rear working light
- / Alarm light
- / Emergency switch
- / Right and left reflective mirrors
- / PVC ceiling
- / Wet brake

Options

- / Front windshield and wipers
- / Cab (warm air blower and fan are available for option)
- / Solid tyre
- / Engine cover with lock
- / Engine cover with dual sound insulation cushion
- / Engine cover with lock+ dual sound insulation cushion
- / Mud baffle provided with rigging hole
- / 3rd/4th/5th valve
- / Voice type reversing buzzer
- / Blue light lamp
- / Low-temperature cold start-up battery (-20 C)
- / OPS system
- / OPS system & Compatible with Sequential Seat Belt Interlock System



2WD/4WD Rough Terrain Forklift

Distinguishing mark	HANGCHA GROUP CO.,LTD.				
	1.1 Manufacturer	CPCD50-XW65C-RT4	CPCD50-XW70C-RT4	CPCD50-XW65E-RT2	CPCD50-XW70E-RT2
1.2 Manufacturer's type designation					
1.3 Drive: electric (battery or mains), diesel, petrol, fuel gas		Diesel	Diesel	Diesel	Diesel
1.4 Operator type: hand, pedestrian, standing, seated, order-picker		Seated	Seated	Seated	Seated
1.5 Rated capacity/rated load	Q (kg)	5000	5000	5000	5000
1.6 Load centre distance	c (mm)	600	600	600	600
1.8 Load distance, centre of drive axle to fork	x (mm)	735	735	735	735
1.9 Wheelbase	y (mm)	2150	2150	2150	2150
2.1 Service Weight	kg	8900	8900	8700	8700
2.2 Axle loading, laden front/rear	kg	12300/1600	12300/1600	12200/1500	12200/1500
2.3 Axle loading, unladen front/rear	kg	4250/4650	4250/4650	4150/4550	4150/4550
3.1 Tyres: solid rubber, superelastic, pneumatic, polyurethane		Pneumatic	Pneumatic	Pneumatic	Pneumatic
3.2 Tyre size, front		445/65-22.5	445/65-22.5	445/65-22.5	445/65-22.5
3.3 Tyre size, rear		12.5/80-18	12.5/80-18	12.5/80-18	12.5/80-18
3.5 Wheels, number front / rear (x = driven wheels)		4x4	4x4	4x2	4x2
3.6 Tread, front	b10 (mm)	1660	1660	1660	1660
3.7 Tread, rear	b11 (mm)	1760	1760	1760	1760
4.1 Tilt of mast/fork carriage forward/backward	α / β (°)	15/15	15/15	15/15	15/15
4.2 Height, mast lowered	h1 (mm)	2685	2685	2685	2685
4.3 Free lift	h2 (mm)	260	260	260	260
4.4 Lift	h3 (mm)	3000	3000	3000	3000
4.5 Height, mast extended	h4 (mm)	4534	4534	4534	4534
4.7 Height of overhead guard (cabin)	h6 (mm)	2575	2575	2575	2575
4.19 Overall length	l1 (mm)	4865	4865	4865	4865
4.20 Length to face of forks	l2 (mm)	3665	3665	3665	3665
4.21 Overall width	b1 (mm)	2105	2105	2105	2105
4.22 Fork dimensions ISO 2331	s/e/l (mm)	60×150×1220	60×150×1220	60×150×1220	60×150×1220
4.23 Fork carriage DIN 15 173 --- ISO 2328, class/type A,B		B	B	B	B
4.24 Fork-carriage width	b3 (mm)	1950	1950	1950	1950
4.25 Distance between fork-arms	bs (mm)	290-1950	290-1950	290-1950	290-1950
4.31 Ground clearance, laden, below mast	m1 (mm)	385	385	385	385
4.32 Ground clearance, centre of wheelbase	m2 (mm)	370	370	370	370
4.34 Aisle width	Ast (mm)	6305	6305	6305	6305
4.35 Turning radius	Wa (mm)	4150	4150	3550	3550
5.1 Travel speed, laden/unladen	km/h	25/25	25/25	25/25	25/25
5.2 Lift speed, laden	m/s	0.45/0.52	0.45/0.52	0.45/0.52	0.45/0.52
5.3 Lowering speed, laden	m/s	0.5/0.43	0.5/0.43	0.5/0.43	0.5/0.43
5.5 Drawbar pull, laden	N	85000	95000	77000	82000
5.7 Gradeability, laden	%	45	55	39	42
5.10 Service brake		Hydraulic	Hydraulic	Hydraulic	Hydraulic
Parking brake		Mechanical	Mechanical	Mechanical	Mechanical
7.1 Engine manufacturer/type		DEUTZ TCD 3.6 L4	QSF3.8t3TC115	DEUTZ TCD 3.6 L4	QSF3.8t3TC115
Emission STD		EURO IIIB/Tier4F	EURO IIIA/GB3	EURO IIIB/Tier4F	EURO IIIA/GB3
7.2 Engine power according to DIN ISO 1585	kw/r/min	55.4/2300	86/2200	55.4/2300	86/2200
7.3 Rated speed	N-m/r/min	390/1300	470/1100-1700	390/1300	470/1100-1700
7.4 Number of cylinders/displacement	(-)/(cm ³)	4/3620	4/3760	4/3620	4/3760
7.10 Battery voltage/nominal capacity	V/Ah	24/90	24/90	24/90	24/90
10.3 Hydraulic Tank - capacity (drain & refill)	liter	115	115	115	115
10.4 Fuel tank capacity	liter	120	120	120	120

5t Mast: (pneumatic)

Type	Model	Max.fork height	Overall height				Free lift		Front Overhang	Tilt range	
			Lowered (mm)	Extended		Without backrest (mm)	With backrest (mm)	5t		FwD	BwD
				Without backrest (mm)	With backrest (mm)						
Wide view mast	RTCS0M300	3000	2685	4183	4534	160	160	735	15	15	
	RTCS0M330	3300	2835	4483	4834	160	160	735	15	15	
	RTCS0M350	3500	2935	4683	5034	160	160	735	15	15	
	RTCS0M370	3700	3035	4883	5234	160	160	735	15	15	
	RTCS0M400	4000	3185	5183	5534	160	160	735	15	15	
	RTCS0M450	4500	3485	5685	6034	160	160	735	15	15	
Wide view full free triplex mast	RTCS0M500	5000	3735	6185	6534	160	160	735	15	15	
	RTCS0N400	4000	2760	5470	5534	1300	1051	804	15	15	
	RTCS0N430	4300	2850	5740	5834	1420	1141	804	15	15	
	RTCS0N450	4500	2910	5920	6034	1500	1201	804	15	15	
	RTCS0N480	4800	3010	6220	6334	1600	1301	804	15	15	
	RTCS0N500	5000	3060	6399	6534	1671	1351	804	10	15	
RTCS0N550	5500	3260	6970	7034	1800	1551	804	10	15		
RTCS0N600	6000	3410	7420	7534	2000	1701	804	10	15		

